



technical data sheet

Description :

OFFICE SERIES WALL MOUNTING CABINETS **Front glass door**

OFFICE series wall mounting cabinets with reduced depth are ideal for the housing of the necessary equipment to the realization of small structured cabling systems.

CODE	DESCRIPTION	OVERALL DIMENSIONS (mm)			WEIGHT	BEAR
		W	D	H	Kg	Kg
2010021	Cabinet 19" 600x320x6U	600	320	387	11,5	30



GENERAL FEATURES

- Steel sheet structure with not-removable side panels
- Front safety glass door, reversible by easy remove system with lock and keys, 180° opening
- Cable inlets from top and bottom
- Front 19" galvanized uprights adjustable in depth according to IEC 60297-1
- Colour : RAL 7035
- Equipped for grounding
- IP 20 protection degree according to EN 60529

Packaging: cardboard

QUBIX S.p.A. Networking solutions – Via Canada, 22/A – 35127 Padova – Italy
Tel. +39 049 7801994 – Fax +39 049 775667 – <http://www.qubix.it>

Rev. 01-19

Qubix S.p.A. si riserva di apportare modifiche e migliorie in qualsiasi momento senza preavviso
Qubix S.p.A. reserves the right to make changes and improvements at any time without notice



technical data sheet

Description :

OFFICE SERIES WALL MOUNTING CABINETS
Front glass door

TECHNICAL DRAWINGS

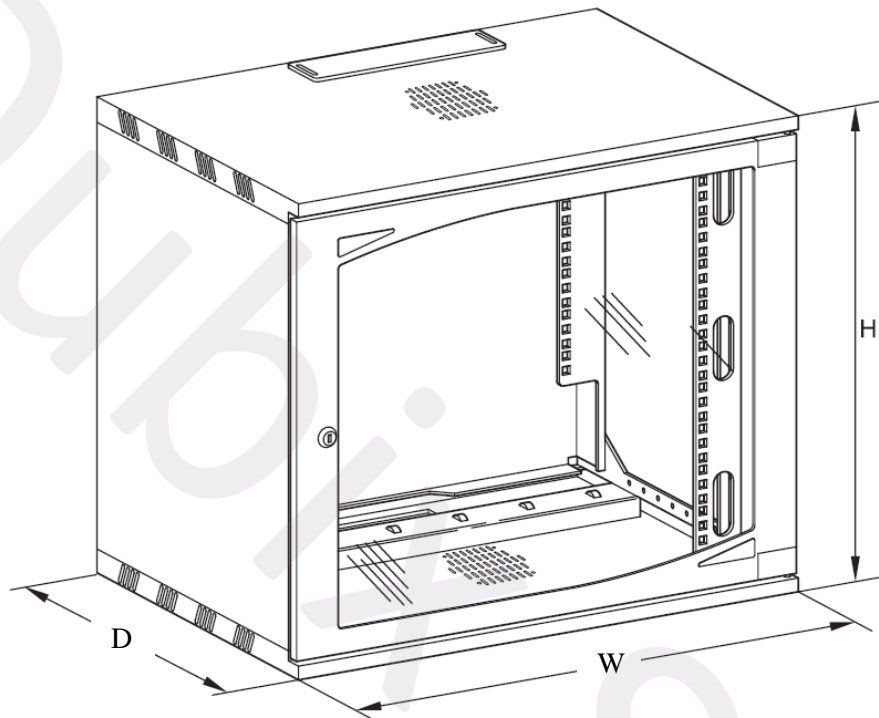

QUBIX S.p.A. Networking solutions – Via Canada, 22/A – 35127 Padova – Italy
Tel. +39 049 7801994 – Fax +39 049 775667 – <http://www.qubix.it>

Rev. 01-19

Qubix S.p.A. si riserva di apportare modifiche e migliorie in qualsiasi momento senza preavviso
Qubix S.p.A. reserves the right to make changes and improvements at any time without notice